



PRODUCT
PAGE

To stay light
and compact

CUSTOM PUMPS ON REQUEST



- The FPT-HTW-C is a compact pump that provide the power for your torque wrenches.
- The FPT-HTW-C10 Series is available in both single port models for single tool operation and quad port models for running up to four tools simultaneously.
- The sight glasses enable operator to monitor reservoir oil levels and the transport cage for all around protection and easy handling.
- The hydraulic pump is available in electric or pneumatic version, with different 2-Stage delivery.
- For this model are available different accessories. For both version the heat exchanger, quick couplers and twin hoses, for FPT9-HTW-C10 the quad block and the auto cycle - for automatic operation. It is also possible totally customize the pump up to the customers' needs.

FPT-HTW-C

700 bar
Two speed
3,5/0,45 - 7,9/0,9 l/m
5 to 10 l capacity

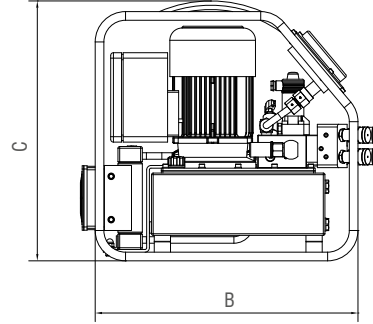
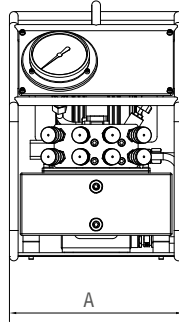
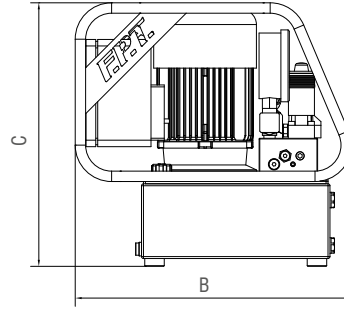
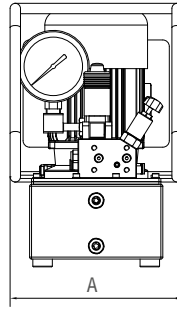

FPT-HTW-C

CODE	MODEL	PRESSURE	OIL FLOW	MOTOR	TENSION/ FREQUENCY	POWER/ RPM	TANK CAPACITY	DIMENSIONS (mm)			WEIGHT
		1" / 2" STAGE						bar	l/min	A	
51001	FPT9-ME41-HTW-C05	80/700	3,5/0,45	MONO PHASE ELECTRIC	230V-50Hz	0,75/1370	5	265	425	405	29
51002	FPT9-ME41-HTW-C05-SC	80/700	3,5/0,45	MONO PHASE ELECTRIC	230V-50Hz	0,75/1370	5	265	425	405	34
51088	FPT9-ME21-HTW-C05-SC	80/700	7,5/0,9	MONO PHASE ELECTRIC	230V-50Hz	1,5/2850	5	265	425	405	34
51003	FPT9-MA-HTW-C05	80/700	5,6/0,65	PNEUMATIC	-	1,3/3000	5	265	425	405	27
51004	FPT9-ME21-HTW-C10	80/700	7,5/0,9	MONO PHASE ELECTRIC	230V-50Hz	1,5/2850	10	320	485	480	36
51005	FPT9-ME21-HTW-C10-SC	80/700	7,5/0,9	MONO PHASE ELECTRIC	230V-50Hz	1,5/2850	10	320	485	480	40
51006	FPT9-ME21-HTW-C10-Q	80/700	7,5/0,9	MONO PHASE ELECTRIC	230V-50Hz	1,5/2850	10	320	485	480	38
51008	FPT9-ME21-HTW-C10-SC-Q	80/700	7,5/0,9	MONO PHASE ELECTRIC	230V-50Hz	1,5/2850	10	320	485	480	43
51009	FPT9-ME21-HTW-C10-SC-Q-AC	80/700	7,5/0,9	MONO PHASE ELECTRIC	230V-50Hz	1,5/2850	10	320	485	480	44
51011	FPT9-ME21-HTW-C10-AC-SC	80/700	7,5/0,9	MONO PHASE ELECTRIC	230V-50Hz	1,5/2850	10	320	485	480	42
51012	FPT9-MA-HTW-C10	80/700	7,9/0,9	PNEUMATIC	-	3/3000	10	320	485	480	34
51013	FPT9-MA-HTW-C10-Q	80/700	7,9/0,9	PNEUMATIC	-	3/3000	10	320	485	480	36

OPTIONS

SC HEAT EXCHANGER

Q QUAD BLOCK

AC AUTO CYCLING

