



PRODUCT
PAGE

When is needed a
very high flow

CUSTOM PUMPS ON REQUEST



- The pump FPT-HTW-HF is a high flow version typically used for intensive job with multiple tools.
- The pump is available on three-phase version with 15 l/min at 100 bar and 3 l/min at 700 bar.
- The pump is equipped with protection cage and wheels for easy handling.
- Standard for this model are: heater exchanger, quad block manifold and oil return filter.
- There are also available different accessories: automatic cycle, quick couplers and twin hoses.
- The FPT-HTW-HF can also be equipped with different pumps and flow related to the torque specifications.
- Automatic cycle available for heavy duty operations.

FPT-HTW-HF

700 bar
15/3 l/min
Two speed
40 l capacity

FPT-HTW-HF

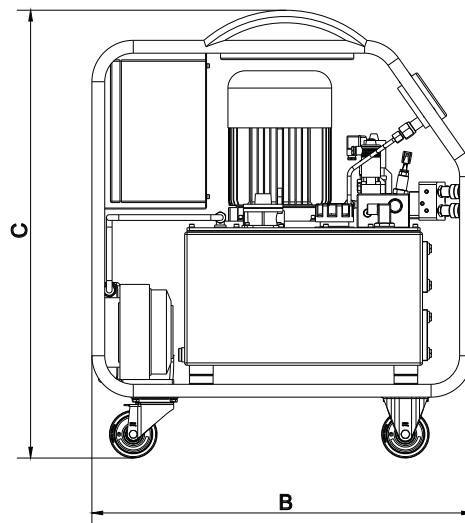
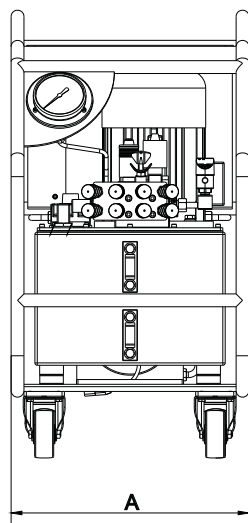

CODE	MODEL	PRESSURE	OIL FLOW	MOTOR	TENSION/ FREQUENCY	POWER/RPM	TANK CAPACITY	DIMENSIONS (mm)			WEIGHT
		1°/2° STAGE	l/min					A	B	C	
51086	FPT15-ME4-HTW-HF40	100/700	15/3	THREE PHASE	400V-50Hz	4/1450	40	500	800	940	100
51087	FPT15-ME4-HTW-HF40-AC	100/700	12/3	THREE PHASE	400V-50Hz	4/1450	40	500	800	940	100

