

FPT

FLUID POWER TECHNOLOGY

HYDRAULIC TORQUE WRENCHES

SQUARE DRIVE, LOW CLEARANCE AND PUMPS



Hydraulic torque wrenches square drive | HTW-BT Series



- Max working pressure 700 bar
- Designed for tightening and loosening.
- 10 different models from 110 Nm up to 72.000 Nm torque power.
- Accuracy $\pm 3\%$ across the full stroke.
- $360^\circ \times 180^\circ$ multi-positional swivel quick release couplings.
- Suitable for continuous operation at maximum pressure.
- High resistance with aluminum-titanium and light body.
- 360° adjustable reaction arm with safety lock feature.

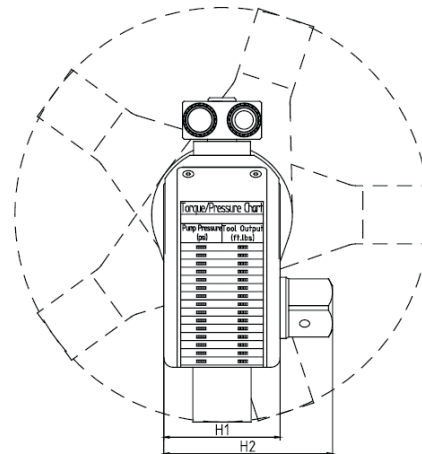
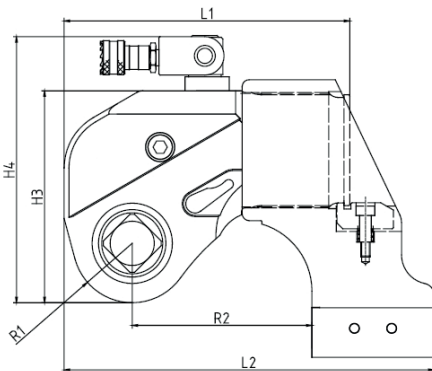

HTW-BT Series

MODEL	SQUARE DRIVE	TORQUE RANGE (Nm)		WEIGHT Kg	DIMENSIONS (mm)							
		MIN	MAX		L1	L2	H1	H2	H3	H4	R1	R2
07 HTW-BT	3/4"	112	1.120	1,80	111	139	42	66	76	108	21	68
1 HTW-BT	3/4"	183	1.837	2,50	145	174	50	72	96	131	26	85
3 HTW-BT	1"	451	4.512	5,00	178	229	68	95	127	177	34	114
5 HTW-BT	1-1/2"	752	7.528	8,00	211	271	80	123	149	199	39	137
8 HTW-BT	1-1/2"	1.078	10.780	11,00	222	293	90	134	167	217	47	153
10 HTW-BT	1-1/2"	1.551	15.516	15,00	246	318	100	142	182	232	51	154
20 HTW-BT	2-1/2"	2.666	26.664	26,50	308	384	120	183	220	270	59	186
25 HTW-BT	2-1/2"	3.472	34.725	35,00	323	401	137	200	247	297	66	199
35 HTW-BT	2-1/2"	4.866	48.666	50,00	373	497	153	216	282	332	77	241
50 HTW-BT	2-1/2"	7.200	72.000	87,00	400	516	160	223	291	341	81	259

Square drive hydraulic torque wrenches | HTW-S Series

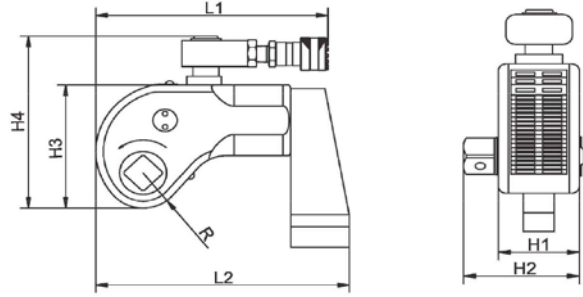

- Available a wide range of accessories such as twin hoses, reductions, reaction arms, sockets.

- Available a wide range of electric and air pumps for different applications.

HTW-S Series

MODEL	SQUARE DRIVE	TORQUE RANGE (Nm)		WEIGHT Kg	DIMENSIONS (mm)						
		MIN	MAX		L1	L2	H1	H2	H3	H4	R
17 HTW-S	3/4"	172	1.727	2	129	167	51	73	90	131	25
45 HTW-S	1"	452	4.529	4,60	167	218	68	98	121	170	34
100 HTW-S	1-1/2"	1.006	10.064	10	223	293	92	135	163	211	46
150 HTW-S	1-1/2"	1.497	14.974	15	264	323	100	141	177	225	50
370 HTW-S	2-1/2"	3.699	36.992	32	329	432	137	104	240	288	66

Low clearance hydraulic torque wrenches | HTW-LOW Series

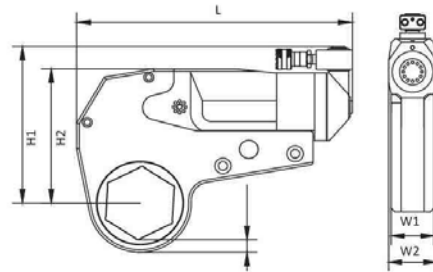

- Repeatability $\pm 3\%$
- Max working pressure 700 bar
- 5 different models from 230 Nm to 45.000 Nm
- Designed for tightening and loosening

- 360° x 180° uni swivel quick release couplings
- Maximum torque power with minimum wall thickness
- Various cassettes, adaptors and reducers are available
- Durable structure, aluminum-titanium alloy and light body

HTW-LOW Series

MODEL	TORQUE RANGE (Nm)		HEX				DRIVE UNIT Kg	CASSETTE Kg	DIMENSIONS (mm)				
	MIN	MAX	METRIC		IMPERIAL				L	H1	H2	W1	W2
2 HTW-LOW	232	2.328	19	55	3/4"	2-3/16"	1	1,6	196,4	125,9	102,3	32	51
	241	2.414	60		2-3/8"		1	1,7	196,4	128,5	105	32	51
4 HTW-LOW	585	5.858	34	65	1-3/8"	2-9/16"	2	4,4	245	177	135,7	42	66
	647	6.474	70	80	2-3/4"	3-1/8"	2	4,6	246	187	145,7	42	66
8HTW-LOW	1.094	10.941	41	95	1"5/8	3"3/4	3	8	300	207	169	53	83
	1.177	11.774	100	105	3-15/16"	4-1/8"	3	8,4	301	216	178	53	83
14 HTW-LOW	1.852	18.521	50	117	2"	4-5/8"	6	11,6	361	239	204	64	99
30 HTW-LOW	4.188	41.882	85	155	3-3/8"	6-1/8"	11	29	430	303	272	85	131
	4.459	44.593	160	175	6-5/16"	6-7/8"	11,4	30	441	315	285	85	131

Cassettes – LOW Series – Metric Size

2 LOW				4 LOW				8 LOW				14 LOW				30 LOW			
MODEL	R	A	MAX TORQUE VALUE Nm	MODEL	R	A	MAX TORQUE VALUE Nm	MODEL	R	A	MAX TORQUE VALUE Nm	MODEL	R	A	MAX TORQUE VALUE Nm	MODEL	R	A	MAX TORQUE VALUE Nm
2C-L19	27	16	2.328	4C-L34	36	16	5.858	8C-L41	46	22	10.941	14C-L50	60	31	18.521	30C-L85	78	28	41.882
2C-L22	27	14	2.328	4C-L36	36	15	5.858	8C-L46	46	19	10.941	14C-L55	60	28	18.521	30C-L90	78	27	41.882
2C-L27	27	11	2.328	4C-L41	39	15	5.858	8C-L50	46	17	10.941	14C-L60	60	25	18.521	30C-L95	83	28	41.882
2C-L30	29	12	2.328	4C-L46	42	15	5.858	8C-L55	50	18	10.941	14C-L65	60	22	18.521	30C-L100	83	25	41.882
2C-L32	29	11	2.328	4C-L50	44	15	5.858	8C-L60	52	17	10.941	14C-L70	60	19	18.521	30C-L105	89	28	41.882
2C-L34	31	11	2.328	4C-L55	46	14	5.858	8C-L65	55	17	10.941	14C-L75	63	19	18.521	30C-L110	89	25	41.882
2C-L36	31	10	2.328	4C-L60	50	15	5.858	8C-L70	58	17	10.941	14C-L80	66	19	18.521	30C-L115	95	28	41.882
2C-L41	34	10	2.328	4C-L65	53	15	5.858	8C-L75	60	17	10.941	14C-L85	69	19	18.521	30C-L117	95	27	41.882
2C-L46	37	10	2.328	4C-L70	56	15	6.474	8C-L80	63	16	10.941	14C-L90	72	20	18.521	30C-L120	95	25	41.882
2C-L50	40	11	2.328	4C-L75	59	15	6.474	8C-L85	66	16	10.941	14C-L95	74	19	18.521	30C-L125	101	29	41.882
2C-L55	43	11	2.328	4C-L80	61	15	6.474	8C-L90	69	17	10.941	14C-L100	77	19	18.521	30C-L130	101	26	41.882
2C-L60	46	11	2.414					8C-L95	71	16	10.941	14C-L105	80	19	18.521	30C-L135	104	26	41.882
								8C-L100	75	17	11.774	14C-L110	83	19	18.521	30C-L140	110	29	41.882
								8C-L105	78	17	11.774	14C-L115	87	20	18.521	30C-L145	110	26	41.882
												14C-L117	87	19	18.521	30C-L150	116	29	41.882
																30C-L155	116	26	41.882
																30C-L160	128	36	44.593
																30C-L165	128	33	44.593
																30C-L170	128	30	44.593
																30C-L175	128	27	44.593

Cassettes – LOW Series – Imperial Size

2 LOW				4 LOW				8 LOW				14 LOW				30 LOW			
MODEL	R	A	MAX TORQUE VALUE Nm	MODEL	R	A	MAX TORQUE VALUE Nm	MODEL	R	A	MAX TORQUE VALUE Nm	MODEL	R	A	MAX TORQUE VALUE Nm	MODEL	R	A	MAX TORQUE VALUE Nm
2C-L3/4"	27	16	2.328	4C-L 1-3/8"	36	16	5.858	8C-L 1-5/8"	46	22	10.941	14C-L 2"	60	31	18.521	30C-L 3-3/8"	78	28	41.882
2C-L7/8"	27	14	2.328	4C-L 1-7/16"	36	15	5.858	8C-L 1-13/16"	46	19	10.941	14C-L 2-3/16"	60	28	18.521	30C-L 3-9/16"	78	27	41.882
2C-L1-1/16"	27	11	2.328	4C-L 1-5/8"	39	15	5.858	8C-L 2"	46	17	10.941	14C-L 2-3/8"	60	25	18.521	30C-L 3-3/4"	83	28	41.882
2C-L1-3/16"	29	12	2.328	4C-L 1-13/16"	42	15	5.858	8C-L 2-3/16"	50	18	10.941	14C-L 2-9/16"	60	22	18.521	30C-L 3-15/16"	83	25	41.882
2C-L1-5/16"	29	11	2.328	4C-L 2"	44	15	5.858	8C-L 2-3/8"	52	17	10.941	14C-L 2-3/4"	60	19	18.521	30C-L 4-1/8"	89	28	41.882
2C-L1-3/8"	31	11	2.328	4C-L 2-3/16"	46	14	5.858	8C-L 2-9/16"	55	17	10.941	14C-L 2-15/16"	63	19	18.521	30C-L 4-5/16"	89	25	41.882
2C-L1-7/16"	31	10	2.328	4C-L 2-3/8"	50	15	5.858	8C-L 2-3/4"	58	17	10.941	14C-L 3-1/8"	66	19	18.521	30C-L 4-1/2"	95	28	41.882
2C-L1-5/8"	34	10	2.328	4C-L 2-9/16"	53	15	5.858	8C-L 2-15/16"	60	17	10.941	14C-L 3-3/8"	69	19	18.521	30C-L 4-5/8"	95	27	41.882
2C-L1-13/16"	37	10	2.328	4C-L 2-3/4"	56	15	6.474	8C-L 3-1/8"	63	16	10.941	14C-L 3-9/16"	72	20	18.521	30C-L 4-3/4"	95	25	41.882
2C-L2"	40	11	2.328	4C-L 2-5/16"	59	15	6.474	8C-L 3-3/8"	66	16	10.941	14C-L 3-3/4"	74	19	18.521	30C-L 4-15/16"	101	29	41.882
2C-L2-3/16"	43	11	2.328	4C-L 3-1/8"	61	15	6.474	8C-L 3-9/16"	69	17	10.941	14C-L 3-15/16"	77	19	18.521	30C-L 5-1/8"	101	26	41.882
2C-L2-3/8"	46	11	2.414					8C-L 3-3/4"	71	16	10.941	14C-L 4-1/8"	80	19	18.521	30C-L 5-5/16"	104	26	41.882
								8C-L 3-15/16"	75	17	11.774	14C-L 4-5/16"	83	19	18.521	30C-L 5-1/2"	110	29	41.882
								8C-L 4-1/2"	78	17	11.774	14C-L 4-1/2"	87	20	18.521	30C-L 5-11/16"	110	26	41.882
												14C-L 4-5/8"	87	19	18.521	30C-L 5-15/16"	116	29	41.882
																30C-L 6-1/8"	116	26	41.882
																30C-L 6-5/16"	128	36	44.593
																30C-L 6-1/2"	128	33	44.593
																30C-L 6-11/16"	128	30	44.593
																30C-L 6-7/8"	128	27	44.593

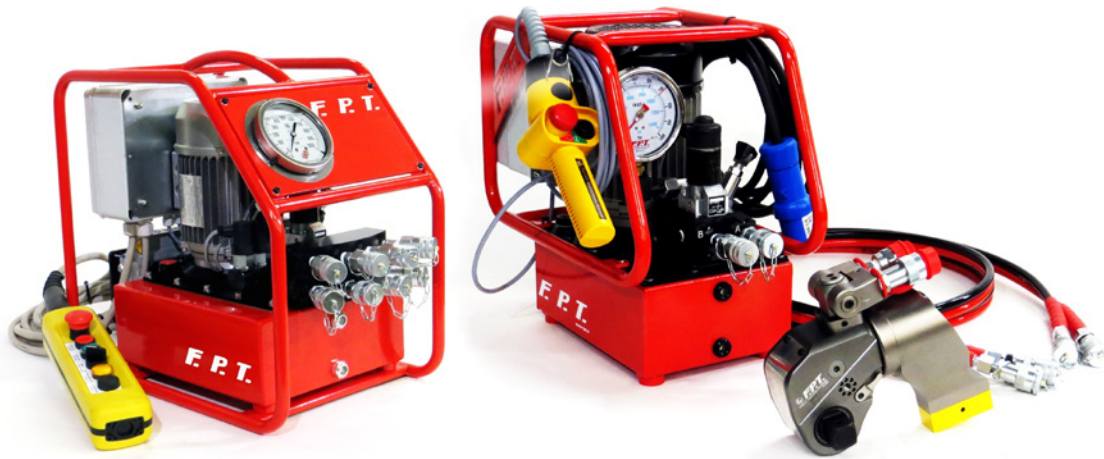

Low clearance hydraulic torque wrenches | HTW-H Series

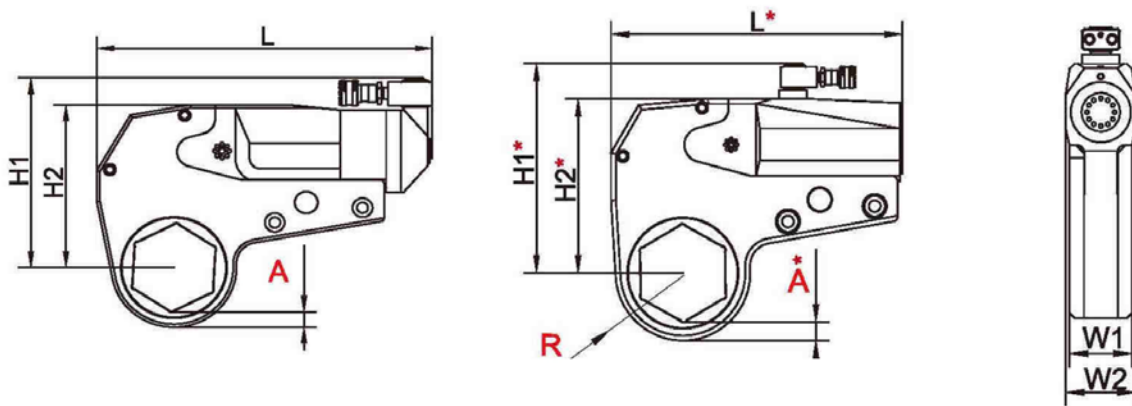

430 HTW-H model

HTW-H Series

MODEL	TORQUE RANGE (Nm)		HEX				DIMENSIONS (mm)					
	MIN	MAX	METRIC		IMPERIAL		L	H1	H2	W1	W2	A
27 HTW-H	262	2.625	19	46	3/4"	1-13/16"	193	125	97	32	51	10-15
	306	3.068	50	60	1-7/8"	2-3/8"	193	136	108	32	51	10-11
54 HTW-H	537	5.372	27	65	1"	2-9/16"	250	158	125	41	64	11-19
	603	6.037	70	80	2-5/8"	3-1/8"	250	169	136	41	64	11,7-12
120 HTW-H	1.173	11.737	50	80	1-7/8"	3-1/8"	310	189	157	52	78	15-15,2
	1.434	14.349	85	105	3-3/16"	4-1/8"	310	214	182	52	78	16-22
210 HTW-H	2.121	21.216	70	100	2-5/8"	3-15/16"	378	223	191	64	97	8-21
	2.312	23.124	105	115	4"	4-5/8"	378	236	204	64	97	18-24
430 HTW-H	4.379	43.792	80	117	3-1/8"	4-5/8"	405*	291*	242*	83	93	25-31*
	4.848	48.481	120	175	4-11/16"	6-7/8"	425*	309*	260*	83	93	25-34*



- Available a wide range of accessories such as twin hoses, reductions, reaction arms, hexagon cassette reducers.
- Available a wide range of electric and air pumps for different applications.

Cassettes - H Series – Metric Size

HTW-27H				HTW-54H				HTW-120H				HTW-210H				HTW-430H			
MODEL	R	A	MAX TORQUE VALUE Nm	MODEL	R	A	MAX TORQUE VALUE Nm	MODEL	R	A	MAX TORQUE VALUE Nm	MODEL	R	A	MAX TORQUE VALUE Nm	MODEL	R	A	MAX TORQUE VALUE Nm
27C-H19	26	15	2.625	54C-H27	36	19	5.372	120C-H50	44	15	11.737	210C-H70	59	18	21.216	430C-H80	72	25	43.792
27C-H22	26	14	2.625	54C-H30	35	17	5.372	120C-H55	47	15	11.737	210C-H75	52	18	21.216	430C-H85	78	28	43.792
27C-H27	26	11	2.625	54C-H32	35	16	5.372	120C-H60	50	15	11.737	210C-H80	65	18	21.216	430C-H90	78	25	43.792
27C-H30	28	11	2.625	54C-H34	35	16	5.372	120C-H65	53	15	11.737	210C-H85	68	21	21.216	430C-H95	84	28	43.792
27C-H32	28	10	2.625	54C-H36	35	14	5.372	120C-H70	56	15	11.737	210C-H90	71	18	21.216	430C-H100	84	26	43.792
27C-H34	31	11	2.328	54C-H41	35	11	5.372	120C-H75	58	15	11.737	210C-H95	77	21	21.216	430C-H105	90	28	43.792
27C-H36	31	10	2.625	54C-H46	37	11	5.372	120C-H80	61	15	11.737	210C-H100	77	18	21.216	430C-H110	94	31	43.792
27C-H41	24	10	2.625	54C-H50	41	12	5.372	120C-H85	66	16	14.349	210C-H105	79	18	23.124	430C-H115	94	28	43.792
27C-H46	37	10	2.625	54C-H55	44	13	5.372	120C-H90	69	16	14.349	210C-H110	87	24	23.124	430C-H117	94	28	43.792
27C-H50	40	11	3.068	54C-H60	47	12	5.372	120C-H95	71	16	14.349	210C-H115	87	21	23.124	430C-H120	101	31	48.481
27C-H55	42	11	3.068	54C-H65	50	12	5.372	120C-H100	77	22	14.349				430C-H125	101	28	48.481	
27C-H60	50	10	3.068	54C-H70	52	12	6.037	120C-H105	77	19	14.349				430C-H130	101	25	48.481	
				54C-H75	56	12	6.037								430C-H135	105	26	48.481	
				54C-H80	58	12	6.037								430C-H140	110	29	48.481	
															430C-H145	110	26	48.481	
															430C-H150	115	29	48.481	
															430C-H155	115	26	48.481	
															430C-H160	121	29	48.481	
															430C-H165	121	26	48.481	
															430C-H170	128	30	48.481	
															430C-H175	128	27	48.481	

Cassettes - H Series – Imperial Size

HTW-27H				HTW-54H				HTW-120H				HTW-210H				HTW-430H			
MODEL	R	A	MAX TORQUE VALUE Nm	MODEL	R	A	MAX TORQUE VALUE Nm	MODEL	R	A	MAX TORQUE VALUE Nm	MODEL	R	A	MAX TORQUE VALUE Nm	MODEL	R	A	MAX TORQUE VALUE Nm
27C-H 3/4"	26	15	2.625	54C-H 1"	34	19	5.372	120C-H 1-7/8"	43	16	11.737	210C-H 2-5/8"	57	19	21.216	430C-H 3-1/8"	70	24	43.792
27C-H 13/16"	26	14	2.625	54C-H 1-1/16"	34	18	5.372	120C-H 1-15/16"	43	15	11.737	210C-H 2-11/16"	57	18	21.216	430C-H 3-3/16"	76	29	43.792
27C-H 7/8"	26	14	2.625	54C-H 1-1/8"	34	17	5.372	120C-H 2"	43	14	11.737	210C-H 2-3/4"	57	17	21.216	430C-H 3-1/4"	76	28	43.792
27C-H 15/16"	26	12	2.625	54C-H 1-3/16"	34	17	5.372	120C-H 2-1/16"	46	16	11.737	210C-H 2-13/16"	60	19	21.216	430C-H 3-5/16"	76	27	43.792
27C-H 1"	26	11	2.625	54C-H 1-1/4"	34	16	5.372	120C-H 2-1/8"	46	15	11.737	210C-H 2-7/8"	60	18	21.216	430C-H 3-3/8"	76	27	43.792
27C-H 1-1/16"	26	10	2.625	54C-H 1-5/16"	34	15	5.372	120C-H 2-3/16"	46	14	11.737	210C-H 2-15/16"	60	17	21.216	430C-H 3-7/16"	76	26	43.792
27C-H 1-1/8"	26	9	2.625	54C-H 1-3/8"	34	14	5.372	120C-H 2-1/4"	49	16	11.737	210C-H 3"	63	19	21.216	430C-H 3-1/2"	76	25	43.792
27C-H 1-3/16"	28	10	2.625	54C-H 1-7/16"	34	13	5.372	120C-H 2-5/16"	49	15	11.737	210C-H 3-1/16"	63	18	21.216	430C-H 3-9/16"	76	30	43.792
27C-H 1-1/4"	28	9	2.625	54C-H 1-1/2"	34	12	5.372	120C-H 2-3/8"	49	14	11.737	210C-H 3-1/8"	63	17	21.216	430C-H 3-5/8"	82	29	43.792
27C-H 1-5/16"	30,63	11	2.625	54C-H 1-9/16"	34	11	5.372	120C-H 2-7/16"	51	16	11.737	210C-H 3-3/16"	66	20	21.216	430C-H 3-11/16"	82	28	43.792
27C-H 1-3/8"	31	10	2.625	54C-H 1-5/8"	34	10	5.372	120C-H 2-1/2"	51	15	11.737	210C-H 3-1/4"	66	19	21.216	430C-H 3-3/4"	82	27	43.792
27C-H 1-7/16"	31	9	2.625	54C-H 1 11/16"	37	12	5.372	120C-H 2-9/16"	51	14	11.737	210C-H 3-5/16"	66	18	21.216	430C-H 3-13/16"	82	26	43.792
27C-H 1-1/2"	34	11	2.625	54C-H 1-3/4"	37	11	5.372	120C-H 2-5/8"	54	16	11.737	210C-H 3-3/8"	66	19	21.216	430C-H 3-7/8"	82	25	43.792
27C-H 1-9/16"	34	10	2.625	54C-H 1-13/16"	37	10	5.372	120C-H 2-11/16"	54	15	11.737	210C-H 3-7/16"	69	19	21.216	430C-H 3-15/16"	82	24	43.792
27C-H 1-5/8"	34	9	2.625	54C-H 1-7/8"	40	13	5.372	120C-H 2-3/4"	54	14	11.737	210C-H 3-1/2"	69	18	21.216	430C-H 4"	87	29	43.792
27C-H 1-11/16"	37	11	2.625	54C-H 1-15/16"	40	12	5.372	120C-H 2-13/16"	57	16	11.737	210C-H 3-9/16"	69	17	21.216	430C-H 4-1/16"	87	28	43.792
27C-H 1-3/4"	37	10	2.625	54C-H 2"	40	11	5.372	120C-H 2-7/8"	57	15	11.737	210C-H 3-5/8"	72	19	21.216	430C-H 4-1/8"	87	27	43.792

Cassettes - H Series – Imperial Size

HTW-27H				HTW-54H				HTW-120H				HTW-210H				HTW-430H			
MODEL	R	A	MAX TORQUE VALUE Nm	MODEL	R	A	MAX TORQUE VALUE Nm	MODEL	R	A	MAX TORQUE VALUE Nm	MODEL	R	A	MAX TORQUE VALUE Nm	MODEL	R	A	MAX TORQUE VALUE Nm
27C-H 1-13/16"	36	9	2.625	54C-H 2-1/16"	43	13	5.372	120C-H 2-15/16"	57	14	11.737	210C-H 3-11/16"	72	18	21.216	430C-H 4-3/16"	87	26	43.792
27C-H 1-7/8"	39	11	3.068	54C-H 2-1/8"	43	12	5.372	120C-H 3"	60	16	11.737	210C-H 3-3/4"	72	17	21.216	430C-H 4-1/4"	87	25	43.792
27C-H 1-15/16"	39	10	3.068	54C-H 2-3/16"	43	11	5.372	120C-H 3-1/16"	60	15	11.737	210C-H 3-13/16"	75	19	21.216	430C-H 4-5/16"	87	25	43.792
27C-H 2"	39	9	3.068	54C-H 2-1/4"	46	13	5.372	120C-H 3-1/8"	60	14	11.737	210C-H 3-7/8"	75	18	21.216	430C-H 4-3/8"	93	29	43.792
27C-H 2-1/16"	42	11	3.068	54C-H 2-5/16"	46	12	5.372	120C-H 3-3/16"	64	18	14.349	210C-H 3-15/16"	75	17	21.216	430C-H 4-7/16"	93	28	43.792
27C-H 2-1/8"	42	10	3.068	54C-H 2-3/8"	46	11	5.372	120C-H 3-1/4"	64	17	14.349	210C-H 4"	77	19	23.124	430C-H 4-1/2"	93	28	43.792
27C-H 2-3/16"	42	9	3.068	54C-H 2-7/16"	49	13	5.372	120C-H 3-5/16"	64	16	14.349	210C-H 4-1/16"	77	18	23.124	430C-H 4-9/16"	93	27	43.792
27C-H 2-1/4"	45	11	3.068	54C-H 2-1/2"	49	12	5.372	120C-H 3-3/8"	64	15	14.349	210C-H 4-1/8"	77	17	23.124	430C-H 4-5/8"	93	26	43.792
27C-H 2-5/16"	45	10	3.068	54C-H 2-9/16"	49	11	5.372	120C-H 3-7/16"	67	16	14.349	210C-H 4-3/16"	80	19	23.124	430C-H 4-11/16"	99	31	48.481
27C-H 2-3/8"	45	9	3.068	54C-H 2-5/8"	51	13	6.037	120C-H 3-1/2"	67	16	14.349	210C-H 4-1/4"	80	18	23.124	430C-H 4-3/4"	99	30	48.481
				54C-H 2-11/16"	51	12	6.037	120C-H 3-9/16"	67	15	14.349	210C-H 4-5/16"	80	17	23.124	430C-H 4-13/16"	99	29	48.481
				54C-H 2-3/4"	51	11	6.037	120C-H 3-5/8"	67	25	14.349	210C-H 4-3/8"	86	22	23.124	430C-H 4-7/8"	99	28	48.481
				54C-H 2-13/16"	54	13	6.037	120C-H 3-11/16"	67	24	14.349	210C-H 4-7/16"	86	21	23.124	430C-H 4-15/16"	99	27	48.481
				54C-H 2-7/8"	54	12	6.037	120C-H 3-3/4"	67	24	14.349	210C-H 4-1/2"	86	20	23.124	430C-H 5"	99	26	48.481
				54C-H 2-15/16"	54	12	6.037	120C-H 3-13/16"	78	23	14.349	210C-H 4-9/16"	86	20	23.124	430C-H 5-1/16"	99	25	48.481
				54C-H 3"	57	13	6.037	120C-H 3-7/8"	78	22	14.349	210C-H 4-5/8"	86	19	23.124	430C-H 5-1/8"	99	25	48.481
				54C-H 3-1/16"	57	13	6.037	120C-H 3-15/16"	78	21	14.349				430C-H 5-3/16"	103	27	48.481	
				54C-H 3-1/8"	57	12	6.037	120C-H 4"	78	20	14.349				430C-H 5-1/4"	103	26	48.481	
								120C-H 4-1/16"	78	19	14.349				430C-H 5-5/16"	103	26	48.481	
								120C-H 4-1/8"	78	18	14.349				430C-H 5-3/8"	103	25	48.481	
															430C-H 5-7/16"	109	30	48.481	
															430C-H 5-1/2"	109	28	48.481	
															430C-H 5-9/16"	109	27	48.481	
															430C-H 5-5/8"	109	27	48.481	
															430C-H 5-11/16"	109	26	48.481	
															430C-H 5-3/4"	109	25	48.481	
															430C-H 5-13/16"	114	29	48.481	
															430C-H 5-7/8"	114	28	48.481	
															430C-H 5-15/16"	114	27	48.481	
															430C-H 6"	114	27	48.481	
															430C-H 6-1/16"	114	26	48.481	
															430C-H 6-1/8"	114	25	48.481	
															430C-H 6-3/16"	120	29	48.481	
															430C-H 6-1/4"	120	28	48.481	
															430C-H 6-5/16"	120	28	48.481	
															430C-H 6-3/8"	120	27	48.481	
															430C-H 6-7/16"	120	26	48.481	
															430C-H 6-1/2"	120	25	48.481	
															430C-H 6-11/16"	128	30	48.481	
															430C-H 6-7/8"	128	27	48.481	

Impact Sockets

E SERIES SQUARE DRIVE - 3/4"					F SERIES SQUARE DRIVE - 1"					G SERIES SQUARE DRIVE - 1 1/2"					H SERIES SQUARE DRIVE - 2 1/2"				
mm	in	CODE	Ø1 mm	L mm	mm	in	CODE	Ø1 mm	L mm	mm	in	CODE	Ø1 mm	L mm	mm	in	CODE	Ø1 mm	L mm
17		E17	31	51	19	3/4"	F19	36.5	58	30	1 3/16	G30	56.5	74	65	2 9/16	H65	106	138
	11/16"	E11/16	32	51	20		F20	38	58	32	1 1/4	G32	59	76		2 5/8	H2.5/8	108	138
18		E18	32	51		13/16"	F13/16	38.5	60		1 5/16	G1.5/16	61	76	70	2 3/4	H70	112.5	140
19	3/4"	E19	33.5	51	21		F21	39	60	34		G34	61.5	76	75	2 15/16	H75	119	143
20		E20	34.5	51	22	7/8"	F22	40	60		1 3/8	G35	63	78		3"	H3	120	143
	13/16"	E13/16	36	51	23		F23	41.5	60	36		G36	64	78	80	3 1/8	H80	125	150
21		E21	36	51	24	15/16"	F24	42.5	60		1 7/16	G1.7/16	65	78		3 1/4	H3.1/4	128	155
22	7/8"	E22	37	51	25		F25	44	60	38	1 1/2	G38	66.5	79	85	3 3/8	H85	131	155
23		E23	38.5	51		1"	F1	45	60		1 9/16	G1.9/16	69	80		3 1/2	H3.1/2	136	160
24	15/16"	E24	39.5	51	26		F26	45	60	41	1 5/8	G41	70	80	90		H90	137.5	160
25		E25	41	51	27	1 1/16	F27	46.5	60		1 11/16	G1.11/16	73	80	95	3 3/4	H95	144	160
	1"	E1	42	51	28		F28	47.5	60		1 3/4	G1.3/4	74.5	84		3 7/8	H3.7/8	148	165
26		E26	42	51		1 1/8	F1.1/8	49	60	46	1 13/16	G46	76.5	84	100		H100	150	165
27	1 1/16	E27	43.5	54	29		F29	49	60		1 7/8	G1.7/8	79	84		4"	H4	152	165
28		E28	44	54	30	1 3/16	F30	50	62	50		G50	81.5	87	105	4 1/8	H105	156	165
	1 1/8	E1.1/8	46	54	32	1 1/4	F32	52.5	63		2"	G2	82.5	87		4 1/4	H4.1/4	160	170
29		E29	46	54	33		F33	54	63	52	2 1/16	G2.1/16	84	87	110		H110	162.5	170
30	1 3/16	E30	47	54		1 5/16	F1.5/16	54	63	54	2 1/8	G2.1/8	86	90	115	4 1/2	H115	169	175
32	1 1/4	E32	49.5	57	34		F34	55	63	55		G55	88	90		4 5/8	H4.5/8	172	175
33		E33	51	57	35	1 3/8	F35	56.5	63	56	2 3/16	G56	88	90	120		H120	175	175
	1 5/16	E1.5/16	52	57	36		F36	57.5	67		2 1/4	G2.1/4	90	90		4 3/4	H4.3/4	176	175
34		E34	52	57		1 7/16	F1.7/16	58	67	60	2 3/8	G60	94	95	125		H125	181	175
35	1 3/8	E35	53.5	57	37		F37	59	67		2 7/16	G2.7/16	96.5	95		5"	H5	184	180
36		E36	54.5	57	38	1 1/2	F38	60	67		2 1/2	G2.1/2	98.5	100	130	5 1/8	H130	188	180
	1 7/16	E1.7/16	56	57		1 9/16	F1.9/16	62	70	65	2 9/16	G65	100	100		5 1/4	H5.1/4	192	180
37		E37	56	57	41	1 5/8	F41	64	70		2 5/8	G2.5/8	102	100	135		H135	194	180
38	1 1/2	E38	57	57	42		F42	65	70	70	2 3/4	G70	106.5	105	140	5 1/2	H140	200	185
	1 9/16	E1.9/16	59.5	57		1 11/16	F1.11/16	66	70		2 13/16	G2.13/16	108	105	145		H145	206	185
41	1 5/8	E41	61	58		1 3/4	F1.3/4	68	76	75	2 15/16	G75	113	110		5 3/4	H5.3/4	208	185
42		E42	62	58	46	1 13/16	F46	70	76		3"	G3	114	110	150		H150	213	190
	1 11/16	E1.11/16	63	58	47		F47	71.5	76	80	3 1/8	G80	119	116		6"	H6	216	195
	1 3/4	E1.3/4	65	63		1 7/8	F1.7/8	72	76		3 1/4	G3.1/4	122	121	155	6 1/8	H155	219	200
46	1 13/16	E46	67	63		1 15/16	F1.15/16	74	82	85	3 3/8	G85	125	121		6 1/4	H6.1/4	223	205
	1 7/8	E1.7/8	69	63							3 1/2	G3.1/2	130	127	160		H160	225	205
50		E50	72	70						90		G90	132	127	165	6 1/2	H165	231	205
	2"	E2	73	70						95	3 3/4	G95	138	127	170		H170	238	210
55		E55	78.5	75							3 7/8	G3.7/8	142	129		6 3/4	H6.3/4	239	210
60	2 3/8	E60	84.5	80						100		G100	144	129	175		H175	244	215
65	2 9/16	E65	91	84							4"	G4	146	129		7"	H7	247	215
70	2 3/4	E70	97	88						105	4 1/8	G105	150	135	180	7 1/8	H180	250	215
											4 1/4	G4.1/4	154	140		7 1/4	H7.1/4	255	220
										110		G110	157	140	185		H185	256	220
										115	4 1/2	G115	163	140	190		H190	263	225
											4 5/8	G4.5/8	166	143		7 1/2	H7.1/2	263	225
										120		G120	169	143	195		H195	269	230
											4 3/4	G4.3/4	170	143		7 3/4	H7.3/4	271	230
										125		G125	175	146	200	7 7/8	H200	275	240
											5"	G5	178	149		8"	H8	279	240
										130	5 1/8	G130	182	149		8 1/4	H8.1/4	287	250
										135		G135	187	150	210		H210	288	250
															215	8 1/2	H215	295	260
															220		H220	300	260
																8 3/4	H8.3/4	303	260
																9"	H9	311	270
															230		H230	313	270
															235	9 1/4	H235	319	270
															240		H340	325	280
															255	10"	H255	342	285

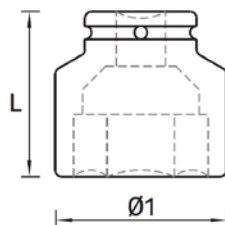



Extending Reaction Arms

DESCRIPTION	MODEL No.	EXTENDING LENGTH (mm)
HTW-LOW Series		
2 HTW LOW Extending Reaction Arm	2 HTW LOW-ARM-21	533
4 HTW LOW Extending Reaction Arm	4 HTW LOW-ARM-21	533
8 HTW LOW Extending Reaction Arm	8 HTW LOW-ARM-21	533
14 HTW LOW Extending Reaction Arm	14 HTW LOW-ARM-21	533
30 HTW LOW Extending Reaction Arm	30 HTW LOW-ARM-21	533
2 HTW LOW Reaction Pad	2LOW-PAD	-
4 HTW LOW Reaction Pad	4LOW-PAD	-
8 HTW LOW Reaction Pad	8LOW-PAD	-
14 HTW LOW Reaction Pad	14LOW-PAD	-
30 HTW LOW Reaction Pad	30LOW-PAD	-
HTW-H Series		
27 HTW H Extending Reaction Arm	27 HTW H-ARM-21	533
54 HTW H Extending Reaction Arm	54 HTW H-ARM-21	533
120 HTW H Extending Reaction Arm	120 HTW H-ARM-21	533
210 HTW H Extending Reaction Arm	210 HTW H-ARM-21	533
430 HTW H Extending Reaction Arm	430 HTW H-ARM-21	533
27 HTW H Reaction Pad	27H-PAD	-
54 HTW H Reaction Pad	54H-PAD	-
120 HTW H Reaction Pad	120H-PAD	-
210 HTW H Reaction Pad	210H-PAD	-
430 HTW H Reaction Pad	430H-PAD	-
HTW-BT Series		
1 HTW BT Extending Reaction Arm	1 HTW BT-ARM21	533
3 HTW BT Extending Reaction Arm	3 HTW BT-ARM21	533
5 HTW BT Extending Reaction Arm	5 HTW BT-ARM21	533
8 HTW BT Extending Reaction Arm	8 HTW BT-ARM21	533
10 HTW BT Extending Reaction Arm	10 HTW BT-ARM21	533
1IBT Reaction Sleeve	1IBT-SLV	-
3IBT Reaction Sleeve	3IBT-SLV	-
5IBT Reaction Sleeve	5IBT-SLV	-
8IBT Reaction Sleeve	8IBT-SLV	-
10IBT Reaction Sleeve	10IBT-SLV	-
HTW-S Series		
HTW S17 Extending Reaction Arm	17 HTW S-ARM21	533
HTW S45 Extending Reaction Arm	45 HTW S-ARM21	533
HTW S100 Extending Reaction Arm	100 HTW S-ARM21	533
HTW S150 Extending Reaction Arm	150 HTW S-ARM21	533
S17 Reaction Sleeve	S17-SLV	-
S45 Reaction Sleeve	S45-SLV	-
S100 Reaction Sleeve	S100-SLV	-
S150 Reaction Sleeve	S150-SLV	-

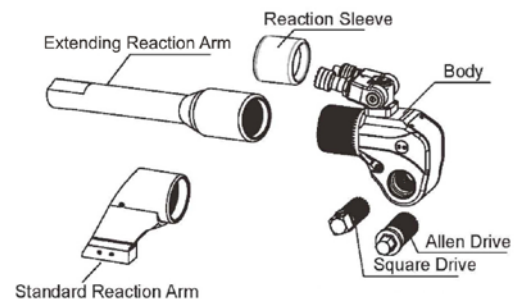
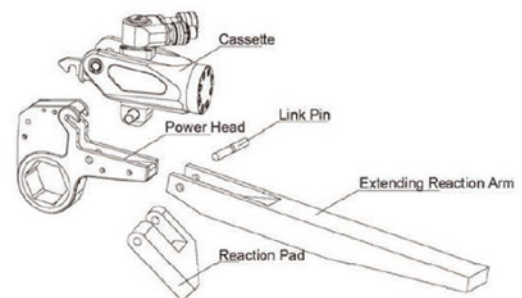

Standard Reducer Insert

Standard Insert Reducer for HTW-LOW AND HTW-H				
HEXAGON CASSETTE LOW	HEXAGON CASSETTE H	REDUCER INSERT		
		MODEL	MODEL	MODEL
2C-L60	27C-H60	G2-60/50	G2-60/46	G2-60/41
2C-L55	27C-H55	G2-55/46	G2-55/41	G2-55/36
2C-L50	27C-H50	G2-50/41	G2-50/36	G2-50/32
2C-L46	27C-H46	G2-46/36	G2-46/32	G2-46/30
2C-L41	27C-H41	G2-41/32	G2-41/30	G2-41/27
2C-L36	27C-H36	G2-36/30	G2-36/27	-
2C-L32	27C-H32	G2-32/27	-	-
4C-L80	54C-H80	G4-80/70	G4-80/65	G4-80/60
4C-L75	54C-H75	G4-75/65	G4-75/60	G4-75/55
4C-L70	54C-H70	G4-70/60	G4-70/55	G4-70/50
4C-L65	54C-H65	G4-65/55	G4-65/50	G4-65/46
4C-L60	54C-H60	G4-60/50	G4-60/46	G4-60/41
4C-L55	54C-H55	G4-55/46	G4-55/41	G4-55/36
4C-L50	54C-H50	G4-50/41	G4-50/36	G4-50/32
4C-L46	54C-H46	G4-46/36	G4-46/32	G4-46/30
4C-L41	54C-H41	G4-41/32	G4-41/30	G4-41/27
4C-L36	54C-H36	G4-36/30	G4-36/27	-
4C-L32	54C-H32	G4-32/27	-	-
8C-L105	120C-H105	G8-105/95	G8-105/90	G8-105/85
8C-L100	120C-H100	G8-100/90	G8-100/85	G8-100/80
8C-L95	120C-H95	G8-95/85	G8-95/80	G8-95/75
8C-L90	120C-H90	G8-90/80	G8-90/75	G8-90/70
8C-L85	120C-H85	G8-85/75	G8-85/70	G8-85/65
8C-L80	120C-H80	G8-80/70	G8-80/65	G8-80/60
8C-L75	120C-H75	G8-75/65	G8-75/60	G8-75/55
8C-L70	120C-H70	G8-70/60	G8-70/55	G8-70/50
8C-L65	120C-H65	G8-65/55	G8-65/50	G8-65/46
8C-L60	120C-H60	G8-60/50	G8-60/46	-
8C-L55	120C-H55	G8-55/46	G8-55/41	-
14C-L117	210C-H117	G14-117/105	G14-117/100	G14-117/95
14C-L115	210C-H115	G14-115/105	G14-115/100	G14-115/95
14C-L110	210C-H110	G14-110/100	G14-110/95	G14-110/90
14C-L105	210C-H105	G14-105/95	G14-105/90	G14-105/85
14C-L100	210C-H100	G14-100/90	G14-100/85	G14-100/80
14C-L95	210C-H95	G14-95/85	G14-95/80	G14-95/75
14C-L90	210C-H90	G14-90/80	G14-90/75	G14-90/70
14C-L85	210C-H85	G14-85/75	G14-85/70	G14-85/65
14C-L80	210C-H80	G14-80/70	G14-80/65	-
14C-L75	210C-H75	G14-75/65	-	-
30C-L175	430C-H175	G30-175/165	G30-175/160	G30-175/155
30C-L170	430C-H170	G30-170/160	G30-170/155	G30-170/150
30C-L165	430C-H165	G30-165/155	G30-165/150	G30-165/145
30C-L160	430C-H160	G30-160/150	G30-160/145	G30-160/130
30C-L155	430C-H155	G30-155/145	G30-155/130	G30-155/120
30C-L145	430C-H145	G30-145/130	G30-145/120	G30-145/115
30C-L135	430C-H135	G30-135/120	G30-135/115	G30-135/110
30C-L130	430C-H130	G30-130/120	G30-130/115	G30-130/110
30C-L120	430C-H120	G30-120/110	G30-120/105	G30-120/100
30C-L115	430C-H115	G30-115/105	G30-115/100	G30-115/95
30C-L110	430C-H110	G30-110/100	G30-110/95	G30-110/90
30C-L105	430C-H105	G30-105/95	G30-105/90	G30-105/85
30C-L100	430C-H100	G30-100/90	G30-100/85	G30-100/80
30C-L95	430C-H95	G30-95/85	G30-95/80	-
30C-L90	430C-H90	G30-90/80	-	-









Backup Wrenches

Backup Wrenches the simplest way to stop a nut rotation.
Mechanical and hands free operation.



Hexagon nut and bolt size

METRIC SIZES		
 Thread size D (mm)	 Hexagon size S (mm)	 Hexagon size J (mm)
M 10	17	8
M 12	19	10
M 14	22	12
M 16	24	14
M 18	27	14
M 20	30	17
M 22	32	17
M 24	36	19
M 27	41	19
M 30	46	22
M 33	50	24
M 36	55	27
M 39	60	27 (30)
M 42	65	32
M 45	70	-
M 48	75	36
M 52	80	36
M 56	85	41
M 60	90	46
M 64	95	46
M 68	100	50
M 72	105	55
M 76	110	60
M 80	115	65
M 85	120	70
M 90	130	70 (75)
M 95	135	-
M 100	145	85
M 105	150	-
M 110	155	-
M 115	165	-
M 120	170	-
M 125	180	-
M 130	185	-
M 140	200	-
M 150	210	-

IMPERIAL SIZES		
 Thread size D (in)	 Hexagon size S (in)	 Hexagon size J (in)
5/8"	1 1/16"	1/2"
3/4"	1 1/4"	5/8"
7/8"	1 7/16"	3/4"
1"	1 5/8"	3/4"
1 1/8"	1 13/16"	7/8"
1 1/4"	2"	7/8"
1 3/8"	2 3/16"	1"
1 1/2"	2 3/8"	1"
1 5/8"	2 9/16"	-
1 3/4"	2 3/4"	1 1/4"
1 7/8"	2 15/16"	1 3/8"
2"	3 1/8"	1 5/8"
2 1/4"	3 1/2"	1 3/4"
2 1/2"	3 7/8"	1 7/8"
2 3/4"	4 1/4"	2"
3"	4 5/8"	2 1/4"
3 1/4"	5"	2 1/4"
3 3/4"	5 3/4"	2 1/4"



Fluid Power Technology S.r.l.

 Via Campo Sportivo 54 - 16040 Ne (Ge) - Italy

 +39 0185 337525

 +39 0185 337620

 info@fpt-worldwide.com

www.fpt-worldwide.com

