

## FPH-MS

700 bar  
Single – double stage  
1,8/0,9 - 7,5/0,9 l/min oil flow  
10 to 25 l oiltank

Series  
**FPH-MS**

## Gasoline driven hydraulic pumps

**Always  
operative**



- The FPH-MS series power units are the ideal solution for all applications where it is not possible to connect electric or air supply.
- Equipped with 4-stroke petrol engine.
- Possibility to install manual, electric or pneumatic, 3 or 4-way valves for single or double-acting cylinders and hydraulic equipment.
- With strong steel tank from 10 to 60 liters.
- The whole series is equipped with a protective cage that simplifies transport and lifting and protects the hydraulic pump on construction sites.
- Wide range of accessories, supplied without quick couplers.
- Possibility to design and produce custom hydraulic pumps on request, with dedicated performance and features.

## CUSTOM HYDRAULIC PUMPS ON REQUEST



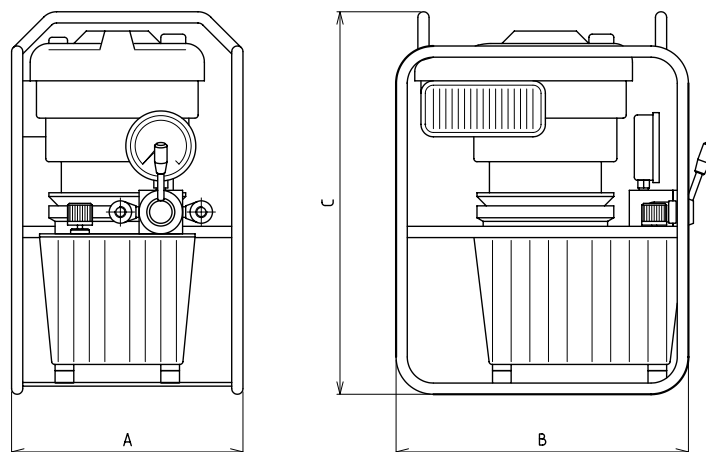

FPH-MS

MODEL	PRESSURE RATING 1st/2nd STAGE	OIL DISPLACEMENT 1st/2nd STAGE	MOTOR	DISPLACEMENT	KW RPM	OILTANK CAPACITY	DIMENSIONS in mm						WEIGHT
	bar	l/min					Cc	litres	A	B	C	D	
FPH 1 - MS	100 /700	1,8 / 0,9	4 STROKE-GASOLINE	161	3 / 3000	10	372	470	615	-	-	-	42
FPH 2 - MS		1,8	4 STROKE-GASOLINE	190	2,6 / 3000		372	470	615	-	-	-	44
FPH 5 - MS		4,5 / 1,8	4 STROKE-GASOLINE	190	2,6 / 3000		372	470	615	-	-	-	44
FPH 9 - MS		7,5 / 0,9	4 STROKE-GASOLINE	161	2,6 / 3000		372	470	615	-	-	-	42