

FPT-GEO

700 bar
 Double stage
 2,5 - 0,9 l/min oil flow
 10 to 60 l oiltank capacity

Series
FPT-GEO

Pump for tests and geotechnics



For automatic pressure recovery

- The most reliable method for determining bearing capacity of a pole is to subject it to a load test. This means planting the pile to the project depth and applying a succession of loads to it.
- FPT GEO series power units perfectly accomplish this task ensuring the maintenance of the pre-set load.
- With the practical microprocessor display it is possible to set the desired pressure. The pump will maintain this value, restoring it in case of leaks or yielding.
- Available with three-phase or single-phase electric motor.
- Protective cage with integrated electrical panel and eyelets for lifting, 20 and 40 liters tank capacity.
- Possibility to design and produce custom hydraulic pumps on request, with dedicated performance and features.
- For years F.P.T. cares of the environment and its protection. It has in fact various products suitable for use with water or fluids 100% biodegradable.



CUSTOM HYDRAULIC PUMPS ON REQUEST



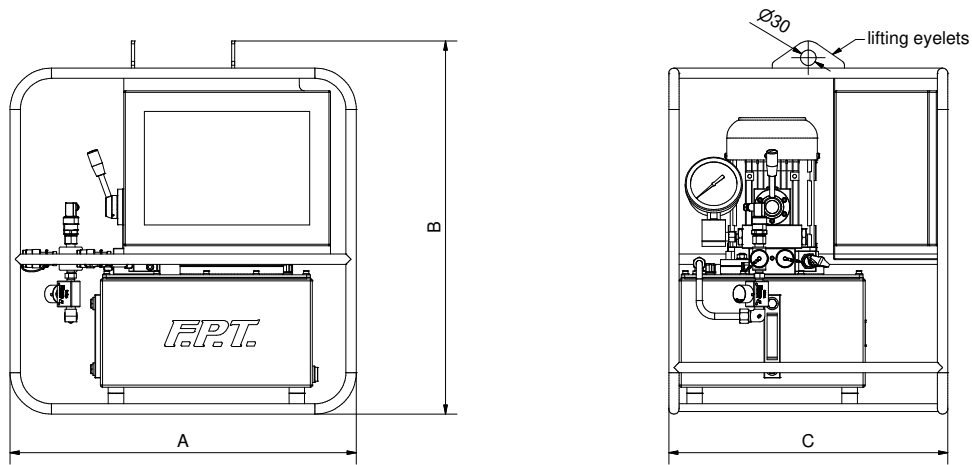

FPT GEO

MODEL	PRESSURE	OIL	MOTOR	VOLTAGE/ FREQUENCY	KW/RPM	OILTANK CAPACITY	DIMENSIONS in mm			WEIGHT
	1st/2nd STAGE	DISPLACEMENT								
	bar	bar		V/Hz		litres				
FPT5-ME4-20-GEO	100/700	2,5/0,9	THREE PHASE ELECTRIC	400V-50Hz	1,1/1440	20	670	772	540	75
FPT5-ME41-20-GEO	100/700	2,5/0,9	MONO PHASE ELECTRIC	230V-50Hz	1,1/1440					75
FPT5-ME4-40-GEO	100/700	2,5/0,9	THREE PHASE ELECTRIC	400V-50Hz	1,1/1440	40				94
FPT5-ME41-40-GEO	100/700	2,5/0,9	MONO PHASE ELECTRIC	230V-50Hz	1,1/1440					94



**FPT – TECH Series HYDRAULIC PUMPS
FOR TESTS AND PRESSING TESTS**

More and more customers need to have a technologically advanced product to perform pressure tests. F.P.T. realizes for this specific sector those power units suitable for operations with water or biodegradable fluids, able of perform pressure tests, record data and be remotely controlled.

Equipped with PLC and dedicated FPT software, they are the ideal tool for all testing and product validation and are completely customizable based on specific customer needs.